



COASTAL COLLECTION DURAWOOD DELUXE DOUBLE PORCH SWING INSTRUCTIONS

NOTE. Instructions not to scale.

CHAIN SET

- CHAIN SETS: (2)
Eye Bolts, nuts, and washers attached

NOTE. Add chains after completing assembly.

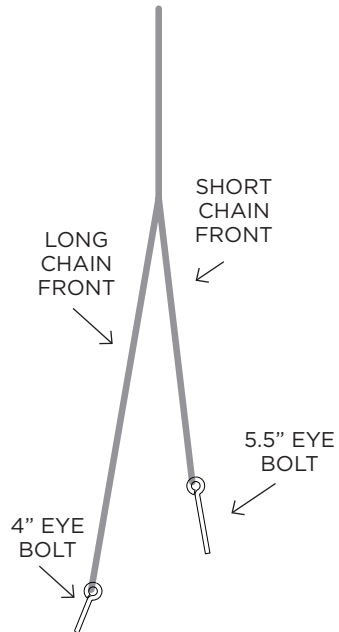

HARDWARE PACK

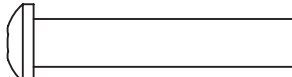
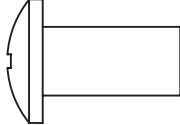
1.  1. BARREL BOLTS:
(4) 1.5", (8) 2.5", (2) 3", (7) 4", (4) 4.5"
2.  2. BARREL NUTS: (25)
3. Hex Key (Not Shown)

CHAIR PARTS

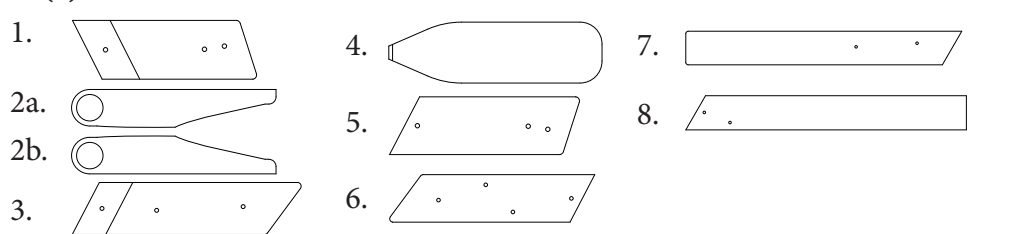
1. (2) FRONT ARM SUPPORTS
 2. ARMS
 - a. Left
 - b. Right
 3. (2) BACK ARM SUPPORTS
 4. TABLE ASSEMBLY
 5. (2) FRONT TABLE LEGS
 6. (2) BACK TABLE LEGS
 7. 2 OUTSIDE UPRIGHTS
 8. CENTER UPRIGHTS
- 

SUGGESTED TOOLS

- RUBBER MALLET
- PHILLIPS HEAD SCREWDRIVER
- 1/2" Wrench
- ALLEN WRENCH

ASSEMBLY

STEP 1. Use (4) 1.5" barrel bolts and (4) barrel nuts to attach left arm and right arm to rear and front arm support.

NOTE. do **not** tighten bolts until Step 5.

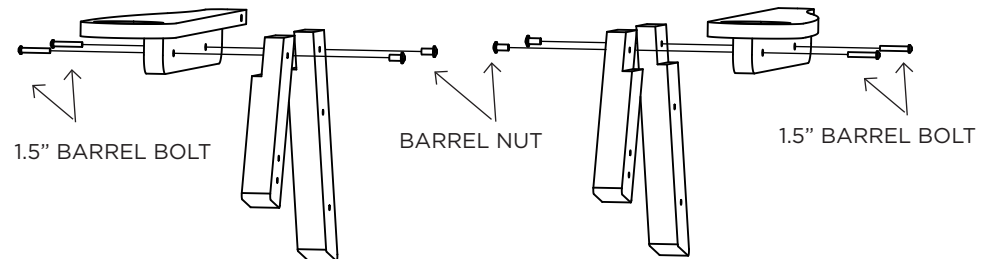

ASSEMBLY

STEP 2. Use (6) 2.5" barrel bolts and (6) barrel nuts to attach arm assemblies to outside of frame.

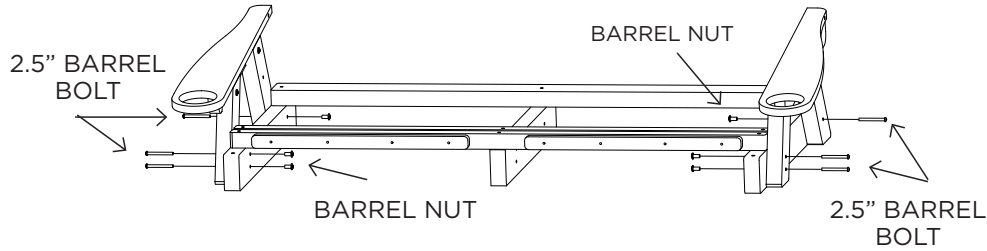

STEP 3. Use (2) 2.5" barrel bolts and (2) barrel nuts to attach frame to left and right supports. Use (2) 3" barrel bolts and (2) barrel nuts to attach left and right uprights to arms.

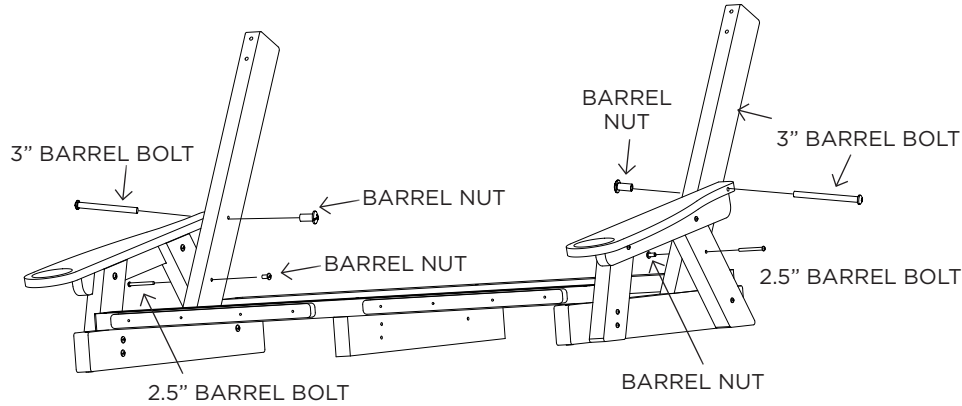

STEP 4. Use (2) 4" barrel bolts and (2) barrel nuts to attach front table legs to center beam. Use (1) 4" barrel bolt and (1) barrel nut to attach back table legs to center beam. Then add table top and use (2) 4" barrel bolts and (2) barrel nuts to attach table legs to bottom of table.

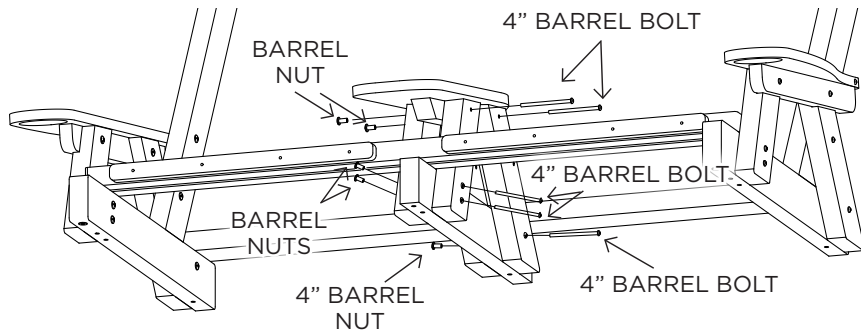

STEP 5. Add the center upright and use (2) 4" barrel bolts and (2) barrel nuts to the back table legs. **(Tabletop hidden to see assembly of hardware)**

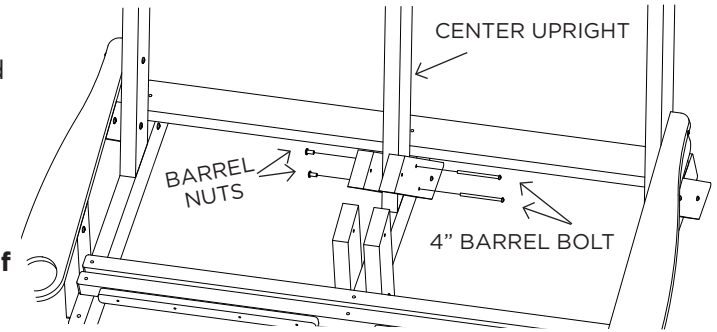

STEP 6. Attach (4) 4.5" barrel bolts, (4) barrel nuts in center beam. **(Eye bolts go on outsides)** Attach chain set to top of uprights using (2) 5.5" eyebolts (short chain) and to front of frame using (2) 4" eyebolts (long chain). Tighten all barrel bolt assemblies and nuts on chain set.

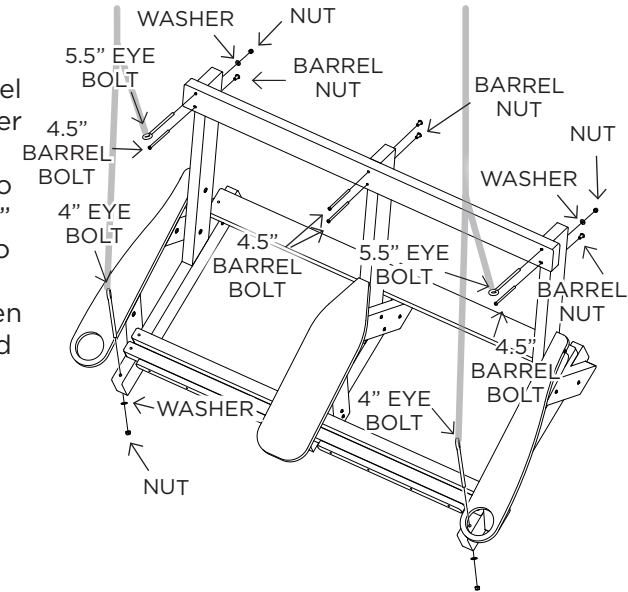

Congratulations on purchasing this Original Cumaru Rope Porch Swing. QUESTIONS REGARDING THIS PRODUCT? Call our customer service team, 1-800-344-6433.

INSTALLATION - Install the ceiling hooks in the overhead support. The hooks should be approximately 5 feet apart. The supports can be ceiling joists, a sturdy limb, or a beam installed for the swing. A ready made stand or instructions to build one are available, please inquire. If the ceiling joists are not exposed, locate one using a stud finder. They are usually 16 to 25 inches apart. Once you find a suitable support, drill a 3/16" starter hole to screw the ceiling hooks into and tighten until the shank is no longer visible. Do not adjust the chains as they are properly connected and able to withstand approximately 500 lbs. of weight. We have replacement chain sets available for sale if needed.

MAINTENANCE - Sunwax Penetrating Wood Feeder™ is recommended as an added protection for wood from insects and weather. It is ideal for cumaru, revitalizes the look of older wood and helps maintain wood's original hue. To clean rope use soap, detergent or a mild bleach solution. Use a soft bristled scrub brush to work on any stains. Be sure to rinse the ropes thoroughly after cleaning.

WARRANTY & RETURNS - Nags Head Hammocks products are guaranteed to be free of defects in both workmanship and material. Prolonged exposure to weather conditions including snow, rain, and humidity are not covered under the warranty, nor is damaged caused by normal wear, mildew, or improper care, including storage, maintenance, and assembly. If you are not satisfied with an item, return it unused in its original packaging for a complete refund or exchange. You can return it to any of our stores or to our warehouse, Nags Head hammocks, 305 Industrial Blvd., Greenville, NC 27834. Please include a copy of your receipt and your contact information.